

# DEA Barrier

## MANUAL OPERATION



**WARNING: BEFORE CARRYING OUT THE RELEASE AND SHUT-DOWN OPERATIONS, MAKE SURE THAT YOU HAVE CUT POWER TO THE OPERATOR.**

### STOP/PASS UNLOCKING SYSTEMS

All STOP and PASS models have an unlocking system; the working of this system is the following. Disconnect power supply from the barrier. Once opened the lock on the case door, this door can be removed.

**WARNING!** There is the danger of hands sharing, in fact there are no protections when accessing to the mechanics levers. Perform all operation in absence of power supply. Take particular care when unlocking. Hold the boom in its front position in order to keep the levers systems stopped. If properly balanced, the boom remains still, opened and closed.

In STOP models, screw, by using the proper key supplied with, the bolt placed in the middle of the gear shaft until the motor unlocks (see F9 page 34). By unscrewing the bolt, the operator returns in its normal working situation.

In PASS models, turn the release handle (see F9 page 34). By turning the handle to its original position, the operator returns in its normal working situation.

PASS

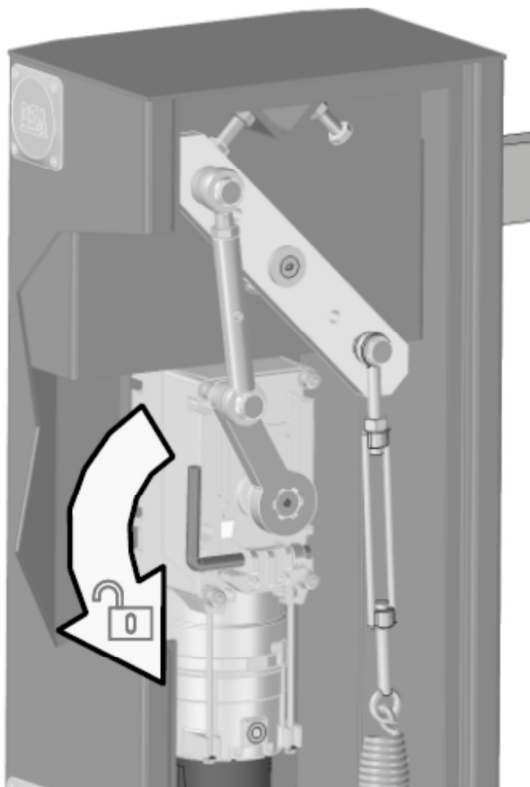

STOP

